

Scheme II

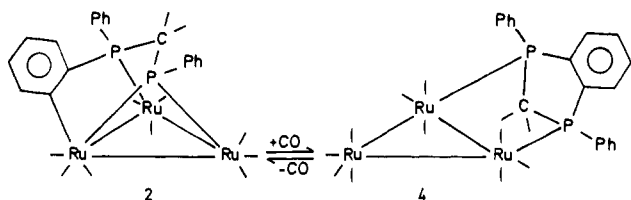

reactions described above show that it undergoes facile reactions on a  $\text{Ru}_3$  cluster. Nevertheless, the dppm fragments thus formed have played their role in the stabilization of the  $\text{Ru}_3$  triangle as it has been retained throughout all reactions investigated. For example,  $\text{Ru}_3(\text{CO})_{10}(\mu\text{-}\eta^2\text{-dppm})$  (**1**) reacts with  $\text{H}_2$  to give the  $\text{Ru}_3\text{H}$  cluster  $\text{Ru}_3(\text{CO})_9(\mu\text{-H})(\mu_3\text{-}\eta^2\text{-P}(\text{C}_6\text{H}_5)\text{CH}_2\text{P}(\text{C}_6\text{H}_5)_2)$  (**3**),<sup>28</sup> whereas the  $\text{Ru}_3$  cluster is not maintained in the reaction of  $\text{Ru}_3(\text{CO})_{12}$  with  $\text{H}_2$ .<sup>30</sup> Compound **3** exhibits remarkable stability as no change is observed when it is heated at 80 °C for 18 h under a pressure of 40 bar of CO. But the mobility of the hydrido ligand in **3** may be important in hydrogenation reactions.

The reaction of **2**,  $\text{Ru}_3(\text{CO})_9(\mu_3\text{-}\eta^3\text{-P}(\text{C}_6\text{H}_5)\text{CH}_2\text{P}(\text{C}_6\text{H}_5)(\text{C}_6\text{H}_4))$ , with CO to afford **4**,  $\text{Ru}_3(\text{CO})_{10}(\mu\text{-}\eta^2\text{-P}(\text{C}_6\text{H}_5)\text{CH}_2\text{P}(\text{C}_6\text{H}_5)(\text{C}_6\text{H}_4))$ , is reversible. These reactions proceed through intramolecular reductive elimination or oxidative addition of the dppm fragment (Scheme II) that could give rise to an intermediate in which atom Ru(3) (Figures 1 and 3) is coordinatively unsaturated. Thus the activation of two-electron donor ligands other than CO in stoichiometric or catalytic carbonylation reactions might be possible.

Finally, the reaction  $1 \rightarrow 2 \rightarrow 4$  can be viewed as the "synthesis" of a new bidentate phosphine ligand,  $(\text{C}_6\text{H}_5)\text{PCH}_2\text{P}(\text{C}_6\text{H}_5)(\text{C}_6\text{H}_4)$ , on a  $\text{Ru}_3$  core, starting from the well-known dppm ligand. The three Ru atoms take part in this process, which demonstrates a cooperative interaction of the metal centers in a cluster to transform an organic substrate.

Finally, the reaction  $1 \rightarrow 2 \rightarrow 4$  can be viewed as the "synthesis" of a new bidentate phosphine ligand,  $(\text{C}_6\text{H}_5)\text{PCH}_2\text{P}(\text{C}_6\text{H}_5)(\text{C}_6\text{H}_4)$ , on a  $\text{Ru}_3$  core, starting from the well-known dppm ligand. The three Ru atoms take part in this process, which demonstrates a cooperative interaction of the metal centers in a cluster to transform an organic substrate.

**Acknowledgment.** This research was supported by the CNRS (ATP "Chimie fine" to J.J.B.), by the NSF (Grant CHE-83-08076 to J.A.I.), and by the NSF/CNRS U.S.-France program (Grant INT-82-12376 to J.A.I.). We thank the Ministère des Relations Extérieures and the Mission Scientifique de l'Ambassade de France in Washington, DC, for enabling Lugan to work in Evanston.

**Registry No.** **1**, 64364-79-0; **2**, 96502-43-1; **3a**, 95402-64-5; **3b**, 95402-64-5; **4**, 96482-75-6.

**Supplementary Material Available:** Tables IIb, IIIb, and IVb, anisotropic thermal parameters for compounds **2**, **3**, and **4**, respectively, and Tables V, VI, and VII, structure amplitudes ( $\times 10$ ) for compounds **2**, **3**, and **4**, respectively (a negative entry for  $|F_o|$  in these latter tables indicates that  $F_o^2 < 0$ ) (92 pages). Ordering information can be obtained from any current masthead page.

(29) Balch, A. L. In "Reactivity of Metal-Metal Bonds"; Chisholm, M. H., Ed.; American Chemical Society: Washington DC, 1981; ACS Symp. Ser. No. 155, pp 167-195.

(30) Knox, S. A. R.; Koepke, J. W.; Andrews, M. A.; Kaesz, H. D. *J. Am. Chem. Soc.* **1975**, *97*, 3942-3947.

## Cyclopropeniumdiazonium Systems: First Generation of a C-sp-Attached Diazonium Function

Robert Weiss,\* Klaus-Georg Wagner, Claus Priesner, and Jürgen Macheleid

Contribution from the Institut für Organische Chemie der Friedrich-Alexander-Universität Erlangen-Nürnberg, D-8520 Erlangen, Federal Republic of Germany. Received August 20, 1984

**Abstract:** Synthesis of stable cyclopropeniumdiazonium salts via several independent pathways is reported. These systems represent the first authentic examples of a diazonium function attached to sp-hybridized carbon. Novel reaction types of these systems include (a) reversible protonation, (b) irreversible hydrolysis, and (c) thermal dediazonation. Experimental results are rationalized on the basis of MNDO model calculations.

### I. Introduction

Despite the high standard of the contemporary synthetic art, not all important functional groups have been attached to carbon via all three main types of C-hybridization. A case in point is the diazonium function which hitherto has only been observed in conjunction with  $\text{sp}^3$  or  $\text{sp}^2$  orbitals of carbon.<sup>1</sup> Alkynyldiazonium salts, A, are the most obvious—though not exclusive (viz. below)—target molecules containing a  $\text{C}_{\text{sp}}$ -attached diazonium function. However, the attempt to synthesize such salts meets with tremendous difficulties. In a classical sense, for the synthesis of A, the existence of primary ynamines would be a prerequisite. These, however, are inaccessible as they are prototropic forms of much more stable nitriles. Other potential precursors (including alkynyl isocyanates<sup>2a</sup> and thionylimines<sup>2b</sup>) would only be accessible

via the corresponding amines. There is one isolated report in the literature<sup>3</sup> which is directly concerned with synthesis and reactivity of a salt A ( $\text{R} = n\text{-C}_4\text{H}_9$ ,  $\text{A}^- = \text{NO}_3^-$ ). The authors claim to have generated this system by reacting the corresponding nitrosoalkyne with NO, thus making use of a very old aprotic diazotization technique.<sup>4</sup> The diazonium salt itself was never directly observed but the authors report its successful trapping via diazo coupling. However, these results have been called in doubt very recently by M. Hanack et al.<sup>5</sup> whose various verification attempts met with total failure. This latter group has approached the synthesis of salts A via dehydrohalogenation reactions of a suitable vinyldiazonium precursor.<sup>6</sup> By working under carefully controlled conditions at low temperature, they were able to collect circumstantial evidence for the intermediacy of A ( $\text{R} = \text{Ph}$ ,  $\text{A}^- = \text{SbCl}_4\text{OTs}^-$ ) by way of various nucleophilic trapping reactions.

(1) Patai, S. "The Chemistry of Diazonium and Diazo Groups"; Wiley: New York, 1978; Part 1 and 2.

(2) (a) Jäger, V.; Viehe, G. H. In "Houben-Weyl-Müller, Methoden der Organischen Chemie", vol. 5/2a, Thieme-Verlag, Stuttgart, 1977; pp 1-920. (b) Viehe, G. H. "Chemistry of Acetylenes"; Marcel Dekker: New York, London, 1969. Both, in (a) and (b), there is no evidence for alkynyl isocyanates and alkynyl thionylimines.

(3) Tedder, J. M.; Robson, E. *Angew. Chem.* **1963**, *75*, 1033.

(4) Bamberger, E. *Ber.* **1918**, *51*, 634.

(5) Hanack, M.; Helwig, R. *Chem. Ber.*, in press.

(6) We are grateful to Prof. Hanack for making a preprint of ref 5 available to us.

Scheme I. Synthesis of Precursors of Cyclopropeniumdiazonium Salts

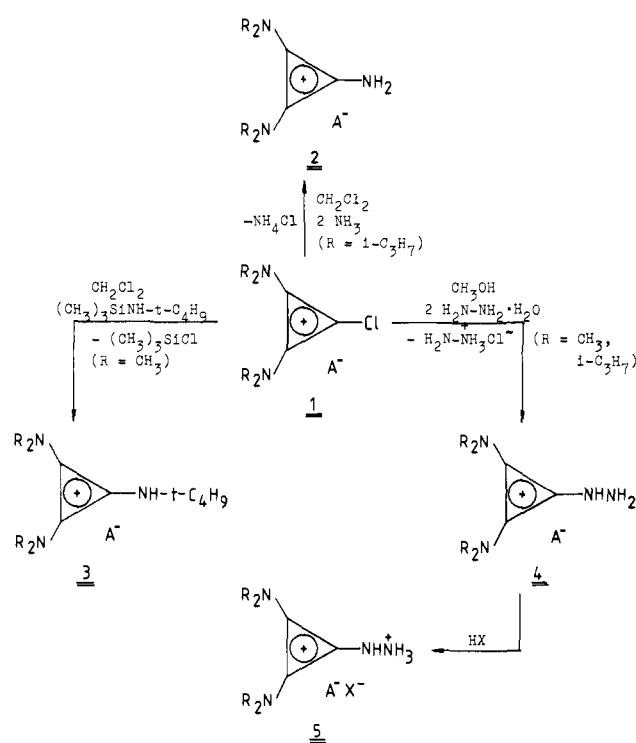

The alkyndiazonium salt itself could not be isolated and characterized.

**Formula A and B.** Yet another system can be conceived which would contain a  $C_{sp}$ -attached diazonium function, namely cyclopropeniumdiazonium salts B. Although tricoordinate, carbon atoms of the cyclopropenium core make use of  $sp$  hybrids in their exocyclic  $\sigma$  bonds. This is a direct consequence of excessive ring

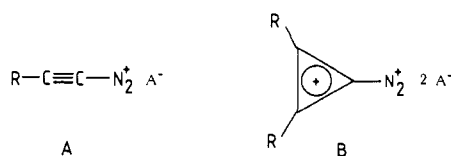

strain, which forces a very high  $p$  weight into the Walsh-type  $\sigma$  orbitals of the ring. This phenomenon is clearly evidenced by  $J_{13C-H}$  measurements on the parent system<sup>7</sup> and its bis(dialkylamino) derivatives.<sup>8</sup> We have concentrated our own efforts on system B, encouraged by the fact that some cyclopropenium systems with primary amino ligands are known<sup>9</sup> and—due to their aromatic character—do not show any signs of unfavorable tautomerism. The difficulty to be anticipated in these systems, however, is the pronounced electrophilicity expected for diazotized species B and the resulting danger of rapid dediazonation and/or cleavage by water and/or other nucleophiles present. It has therefore been our strategy to reduce the electrophilicity of species B by (a) making R good donor groups and (b) excluding nucleophiles (in particular  $H_2O$ ) from the reaction medium. We now report on the generation, properties, and some fundamental chemical reactions of the first diazonium salts of type B ( $R = NR_2$ ) in which the diazonium function is attached to an  $sp$  hybrid of carbon.

## II. Synthesis of Cyclopropeniumdiazonium Salts

Three types of precursors for B are conveniently accessible as shown in Scheme I. All of these reactions proceed smoothly at

Scheme II. Synthesis of Diazonium Salts 6

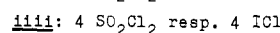
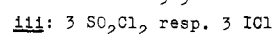
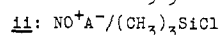
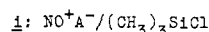
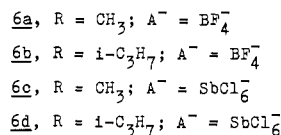
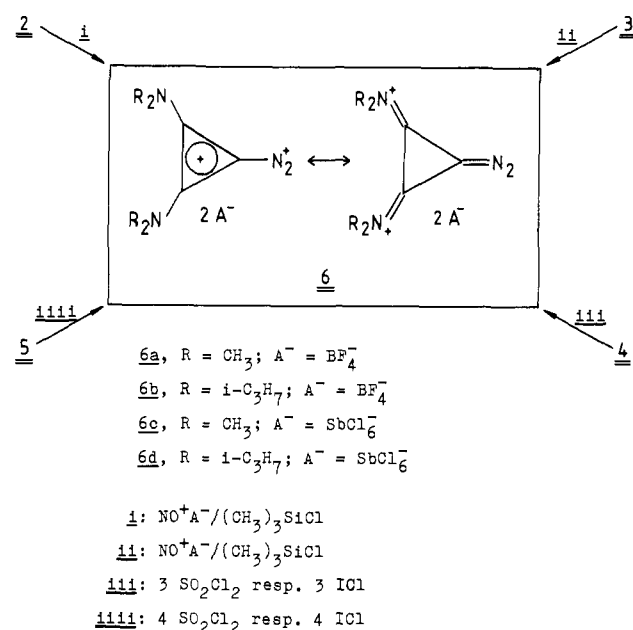

Table I. Characteristic Data of Compounds 6a-d

	yield, %	mp, °C	IR (KBr) ( $\nu(-N\equiv N^+)$ )	( $\nu(C_3^+)$ )	$\bar{\nu}(C_3^+ - \text{unsymm.})$
<b>6a</b>	76-95	51 dec	2155	1900	1605
<b>6b</b>	86-97	80 dec	2130	1870	1570
<b>6c</b>	69-90	73 dec	2145	1945	1600
<b>6d</b>	91-98	96 dec	2130	1900	1575

room temperature in dichloromethane and give high yields of product (usually >80%). Type 2 was a known compound.<sup>9</sup> Salts 3 and 4 had been unknown, but we have now synthesized and fully characterized them. Salts 4 are oxidizable by oxygen and were stabilized by protonation to yield the salts 5. The compounds 2-4 were subsequently transformed according to Scheme II to give identical 1-diazonio-2,3-bis(dialkylamino)cyclopropenium salts 6 as almost colorless moisture-sensitive compounds in fair to good yields.

Route i involves the classical diazotization and is only successful, if water generated in this process is effectively removed. In an early version, we used acetic anhydride<sup>10</sup> for this purpose, but addition of 2 equiv of trimethylchlorosilane to the reaction mixture proved to be a superior method. As 2 with  $R = CH_3$  was inaccessible due to ring opening reactions, we had to devise an alternative method en route to 6. The *de-tert*-butylating diazotization of 3 according to ii is a novel method which works very cleanly for this case. To the best of our knowledge, a dealkylative diazotization is unprecedented. The presence of  $(CH_3)_3SiCl$  is not even required in this case; it seems that the nucleophile  $(CH_3)_3COH$ , most probably generated in this process, is too bulky to attack the electrophilic dication.

A formal  $4e^-$  oxidation accompanied by loss of three protons will convert a hydrazino function into a diazonium function. Several arylhydrazines have thus been oxidatively converted into aryl diazonium salts,<sup>11</sup> but for obvious reasons, this method has found little application. For the present problem, however, it is the method of choice, as no nucleophile is generated in the process. High yield oxidations to 6 were observed with  $ICl$ ,  $SO_2Cl_2$ , and  $SbCl_5$  (but not with  $SbF_5$ ) as oxidants, cf. pathway iii in Scheme II.

In order to protect hydrazinocyclopropenium salts 4 from air oxidation, we converted them into salts 5, which can be stored unchanged for a long time. On oxidation with 4 equiv of  $ICl$  or

(7) (a) Breslow, R. *J. Am. Chem. Soc.* **1957**, *79*, 5318. (b) Breslow, R.; Ryan, G. *J. Am. Chem. Soc.* **1967**, *89*, 3073.

(8) Yoshida, Z.; Konishi, H.; Ogoshi, H. *Isr. J. Chem.* **1981**, *21*, 139.

(9) Yoshida, Z. *Top. Curr. Chem.* **1973**, *40*, 47; no experimental details described.

(10) Priesner, C. Ph.D. Dissertation, University of Munich, 1977.

(11) Pütter, R. In "Houben-Weyl-Müller, Methoden der Organischen Chemie"; Thieme-Verlag: Stuttgart, 1965; Vol. X/3, p 7.

Table II. Hydrolysis Products **8** from **6**

start compd	reaction time, h	prod	yield, %	mp, °C	IR (KBr), cm <sup>-1</sup>	<sup>1</sup> H NMR (CDCl <sub>3</sub> /CD <sub>3</sub> CN) δ, ppm	<sup>13</sup> C NMR (CDCl <sub>3</sub> ) δ, ppm
<b>6a</b>	2	<b>8a</b>	90	158–159 dec	3080 (=CH) 2900 2130 (—N <sub>2</sub> <sup>+</sup> ) 1665 (C=O) 1615 (C=C) 1420	3, 15 (d, 6 H, <i>J</i> = 2 Hz, N—CH <sub>3</sub> ) 3, 35 (d, 6 H, <i>J</i> = 4 Hz, N—CH <sub>3</sub> ) 6, 40 (s, 1 H, C=CH)	
<b>6b</b>	2	<b>8b</b>	95	174–176 dec	3100 (=CH) 2970 2120 (—N <sub>2</sub> <sup>+</sup> ) 1645 (C=O) 1570 (C=C) 1450	1, 41 (mc, 12 H, CH—CH <sub>3</sub> ) 3, 08 (mc, 4 H, CH—CH <sub>3</sub> ) 6, 53 (s, 1 H, C=CH)	18, 6–20, 7 (m) 47, 5 (s), 50, 9 (s) 52, 5 (s), 59, 16 (s) 60, 6 (s), 157, 6 (s) 162, 6 (s)
<b>6c</b>	3, 5	<b>8c</b>	72	165–166 dec	3085 (=CH) 2930 2130 (—N <sub>2</sub> <sup>+</sup> ) 1680 (C=O) 1610 (C=C) 1400	3, 14 (s, 6 H, N—CH <sub>3</sub> ) 3, 37 (d, 6 H, <i>J</i> = 6 Hz, N—CH <sub>3</sub> ) 6, 16 (s, 1 H, C=CH)	

SO<sub>2</sub>Cl<sub>2</sub>, the latter salts than gave even better results as **4**, cf. pathway iv in Scheme II.

As detailed in Table I, the IR spectra of all diazonium salts **6a–d** exhibit an intense (—N≡N<sup>+</sup>) absorption between 2130 and 2155 cm<sup>-1</sup>,<sup>12</sup> as well as strong absorptions around 1600 cm<sup>-1</sup> for the unsymmetrical ring vibration.<sup>4,5</sup> The ring-breathing vibration<sup>9</sup> is observed as a weak signal around 1900 cm<sup>-1</sup>.

Bis(hexachloroantimonates) **6c** and **d** are very little soluble in all common solvents; the bis(tetrafluoroborates) **6a** and **b** are soluble in acetonitrile, but obviously react with this solvent under decomposition. So far no NMR spectra of **6a–d** could be recorded.

### III. MNDO Model Calculations

In order to obtain more insight into the reactivity expected for this new nonbenzenoid aromatic diazonium system, MNDO calculations were performed on the parent system **7**. All mo-

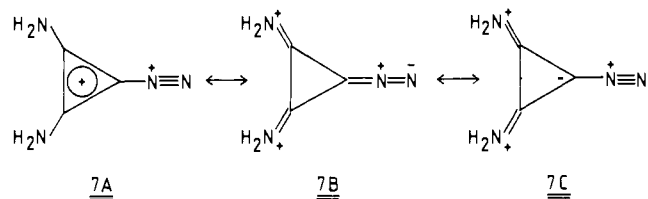

lecular parameters were optimized independently. The results are shown in Figure 1. Inspection of charge distribution, bond orders, and bond lengths shows that the bonding situation in **7** can be approximated by resonance structures **7A–C**. Thus, **7** can be conceived of as a resonance hybrid made up from an acceptor-stabilized cycloaliphatic diazo system (**7B,C**) and a donor-stabilized aromatic diazonium system (**7A**). This bonding pattern is unprecedented.

Inspection of the frontier orbitals of **7** leads to the prediction that electrophilic attack will preferentially take place at C<sub>1</sub> and with much less probability at the amino substituents. Both π and total charge distributions are consistent with this picture. Nucleophiles are expected to favor attack on C<sub>1</sub>, C<sub>2</sub>, or the terminal nitrogen atom of the diazonium function (diazo-coupling reactions). Again this frontier orbital derived conclusion is consistent with charge distributions. Reaction sites of **7** with electrophiles and nucleophiles are summarized in Figure 2.

### IV. Reactions

Reactivity studies on salts **6** turned out to be most problematic. A large number of potential reaction partners—most of them nucleophiles—invariably lead to either no reaction or—more

$$\Delta H_f = 570,2 \text{ kcal/mole}$$

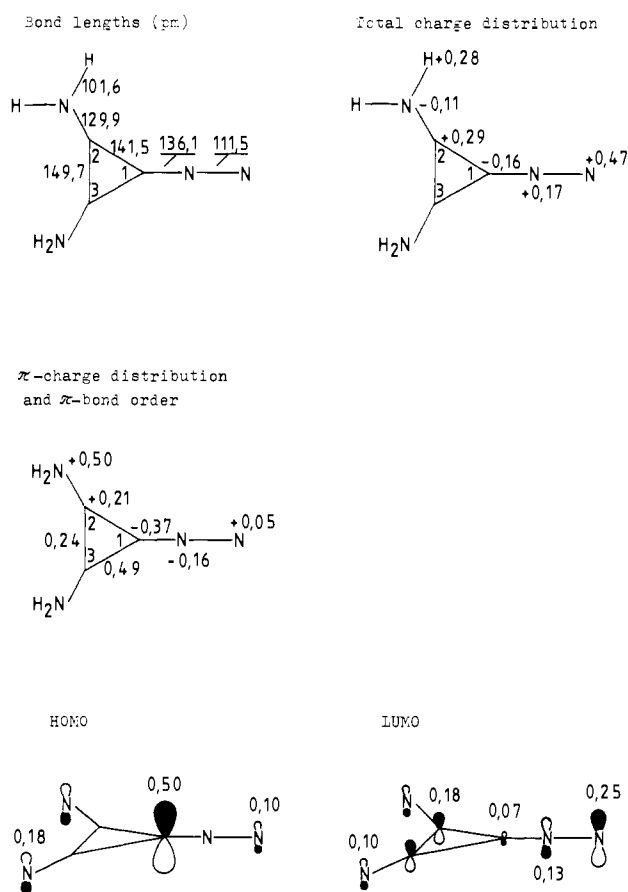

Figure 1. MNDO results for the model system **7**. (Bond lengths are in picometers (pm).)

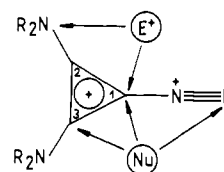
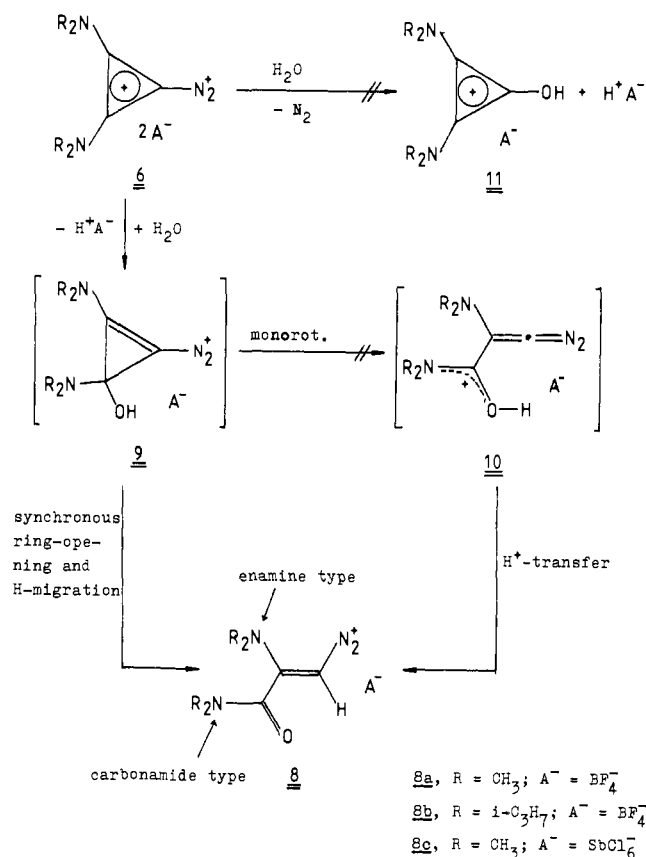

Figure 2. Reaction sites of **7**.

frequently—to a total destruction of the ring, besides loss of nitrogen, resulting in dark oils and tars. However, in spite of that, three different reaction types, each of which is highly characteristic of the unusual structure of **7**, were discovered and will be sub-

(12) This value has to be compared with  $\nu$ -N<sub>2</sub><sup>+</sup> values in arenediazonium salts, which, depending on substitution patterns, range from 2295 to 2110 cm<sup>-1</sup> (cf.: Whetsel, K. B.; Hawkins, G. F.; Johnson, F. E. *J. Am. Chem. Soc.* **1956**, *78*, 3360). The rather low values of  $\nu$ -N<sub>2</sub><sup>+</sup> in **6a–d** indicate a considerable contribution of resonance forms **7B,C**.

Scheme III. Hydrolysis of Salts 6



sequently discussed in some detail.

**A. Hydrolysis.** It turned out that in reactions of **6a-c** with water as a nucleophile, only one of the various possibilities shown in Figure 2 was realized. Salts **6** react smoothly with water in a highly dispersed suspension in dichloromethane to give, as the sole detectable products, ring-opened vinyl diazonium salts **8**, probably via the pathway shown in Scheme III. Table II sums up some relevant data of vinyl diazonium salts **8**. The structure of **8** reveals itself by the occurrence of a new intensive IR band of the diazonium function at around  $2130\text{ cm}^{-1}$  and disappearance of ring vibrations<sup>9</sup> in favor of intensive carbonamide vibrations at around  $1665\text{--}1680\text{ cm}^{-1}$ . The  $^1\text{H NMR}$  spectra show a single vinyl proton and two inequivalent  $\text{R}_2\text{N}$  groups, one of which, probably the enamine-type  $\text{R}_2\text{N}$  group, is rotationally hindered at room temperature. This  $\text{R}_2\text{N}$  group is more likely to be rotationally hindered, because it is connected to the stronger acceptor function.

The mass spectrum of **8b** shows an intense peak at  $m/e$  252; this points to the formation of the acetylene **12a** according to eq 1. All salts **8** analyze correctly for the assumed structure. In-

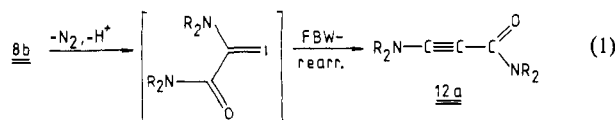

( $\text{R} = i\text{-C}_3\text{H}_7$ )

spection of the  $^1\text{H NMR}$  spectra of **8** (cf. above) shows that only one vinyl diazonium salt is formed stereospecifically, the *Z* isomer given in Scheme III being the more likely one for mechanistic reasons. This results from the following considerations. According to our MNDO calculations (cf. above), both charge distribution and LUMO structure in **6** suggest that nucleophilic attack on the cyclo- $\text{C}_3^+$  subunit of this dication should preferentially occur in the 2/3-position and not in the 1-position. Indeed, **8** can only be generated via the novel cyclopropenyldiazonium salt **9**, in which everything is ideally set up for a highly exothermic donor-ac-

ceptor-assisted cyclopropenol ring opening.<sup>13</sup> It seems most likely that heterolytic bond rupture and proton transfer to the 1-position occurs in a synchronous fashion. This would circumvent the unfavorable vinyl diazo intermediate **10**, which also might be expected to stabilize itself by nitrogen extrusion and rapid FBW rearrangement<sup>14</sup> to a donor-acceptor-substituted alkyne (cf. eq 1), instead of transferring a proton to give **8**.

Salts **8** represent first examples of a new class of functionally substituted vinyl diazonium salts. Vinyl diazonium salts reported so far<sup>15</sup> invariably carry only stabilizing groups at the 2-position.

**B. Thermolysis.** One of the main reasons why one should want to synthesize the C-sp-bound diazonium function is the question of whether by nitrogen extrusion C-sp-centered carbenium ions would become accessible for the first time according to eq 2 and 3. The reaction according to eq 2 is certainly strongly endo-

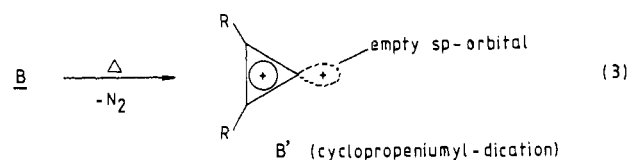
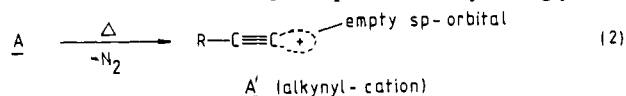

thermic.<sup>16</sup> It is also spin-forbidden as the two degenerate  $\pi$  orbitals are situated well above the "sp hole", so that an electron reallocation resulting in a triplet ground state for  $\text{A}'$  is to be expected.<sup>16</sup> In contrast to eq 2, the related issue (eq 3) can now be studied for model compounds **6**. Experimentally we find that these salts—when heated as solids—start developing nitrogen at temperatures above  $60\text{ }^\circ\text{C}$ . This process was followed quantitatively for **6d**. At  $130\text{ }^\circ\text{C}$  after 0.5 h, 1 mol equiv of nitrogen had developed. Workup of the dark solid residue from this thermolysis showed that—amongst other things—an aromatic substitution of the Baltz-Schiemann-type had taken place (eq 4). **1d** could be

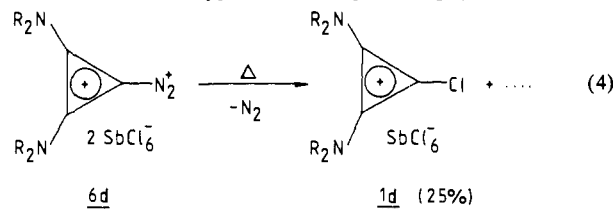

( $\text{R} = i\text{-C}_3\text{H}_7$ )

extracted with dichloromethane from the deeply colored mixture of mostly insoluble reaction products in 25% yield and proved to be identical with an independently synthesized sample.<sup>9</sup> The residue, according to IR scrutiny, does not show any indication of other cyclopropenium-derived products and seems to consist mainly of totally insoluble dark polymers.

Apart from the fact that **6d** does not contain "free" chloride ions, we could show that the corresponding bis(tetrafluoroborate) **6b** in dichloromethane suspension at room temperature does not react with the dication under dediazonation. In fact, the results of hydrolysis show (cf. above) that the dication deploys its electrophilicity in the 2-position, if anything. We conclude that during thermolysis, the cyclopropenyldiazonium system in **6** is converted into an intermediate so electrophilic that it is capable of

(13) Wendisch, D. In "Houben-Weyl-Müller", Methoden der Organischen Chemie"; Thieme-Verlag: Stuttgart, 1977; Vol. 4/3, p 743.

(14) (a) Fritsch, P. *Liebigs Ann. Chem.* **1894**, 279, 319. (b) Buttenberg, W. P. *Ibid.* **1894**, 279, 324. (c) Wiechell, H. *Ibid.* **1894**, 279, 337.

(15) Bott, K. In "S. Patai, The Chemistry of Functional Groups"; Wiley: New York, 1983; Chapter 16, p 671.

(16) Krishnan, R.; Frisch, M. J.; Pople, J. A.; Schleyer, P. v. R. *J. Chem. Phys.* **1981**, 74, 4213-4214.

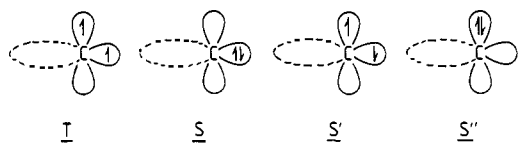
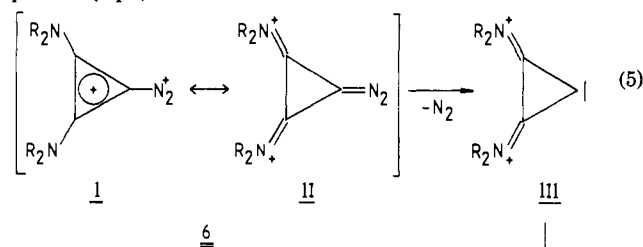

Figure 3. Qualitative ordering of excited states of cyclic carbenes.

abstracting a chloride ion from the coordinatively very stable hexachloroantimonate ion. Attention has therefore to focus on the electronic nature of potential intermediates III, generated in the dediazonization of **6**, assuming that this is an unimolecular process (eq 5). Resonance structure II indicates that this com-



pound can alternatively be considered as a novel radalenoid diazo compound. Unimolecular loss of nitrogen then would lead to the highly strained cyclic carbene III, the further fate of which will critically depend on its electronic configuration.

For larger cyclic carbenes, the qualitative ordering of the four lowest electronic states is thought to be that in Figure 3.<sup>17</sup> For our particular system III, the sequence ordering of states must not necessarily be the same because the  $p_z$  orbital of the carbene carbon atom is incorporated into a Hückel-aromatic system.  $S''$ , which, in our case, corresponds to an aryl cation with a  $sp$  hole, would benefit from this situation relatively more than the other states because of the favorable resonance stabilization in eq 6.

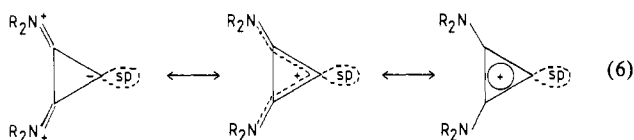

MNDO calculations were performed on model systems of type III with  $R = H$  in order to achieve a better understanding of the dediazonization of III. The  $S$  state is calculated to be  $\sim 3$  kcal/mol more stable than the  $T$  state. STO-3G calculations give a similar ordering.<sup>18</sup>

$S''$  correlates with linear nitrogen extrusion from **7** under spin conservation, and its involvement should result in an extremely powerful Lewis-acid behavior due to the  $sp$  hole created in the process. It would therefore, in principal, meet the structural requirements for a potential precursor of **1d**. MNDO calculations suggest, however, that this is a most unlikely event to occur, as linear nitrogen extrusion turns out to be coupled with an electrocyclic ring opening of the  $C_2-C_3$  bond, according to Scheme IV. This ring-opening process is calculated to have an exceedingly high barrier (about 98 kcal/mol) while being distinctly exothermic. Although this result cannot be taken seriously in its quantitative aspects (MNDO is known to severely underestimate strain.<sup>19</sup> More advanced calculations therefore should come up with a distinctly lower barrier for linear nitrogen extrusion, as this process is directly coupled with a strong release of ring strain.), it

(17) Chapman, O., private communication to R. Weiss.

(18) Clark, T., unpublished results.

(19) (a) Dewar, M. J. S.; McKee, M. L.; Rzepa, H. S. *J. Am. Chem. Soc.* **1978**, *100*, 3607. (b) Dewar, M. J. S.; Thiel, W. *J. Am. Chem. Soc.* **1977**, *99*, 4899.

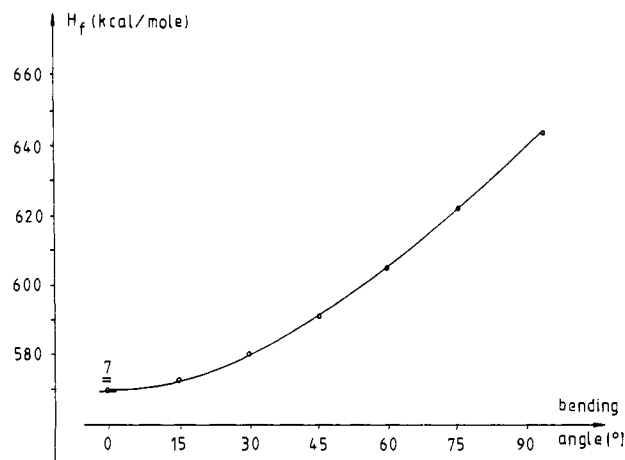
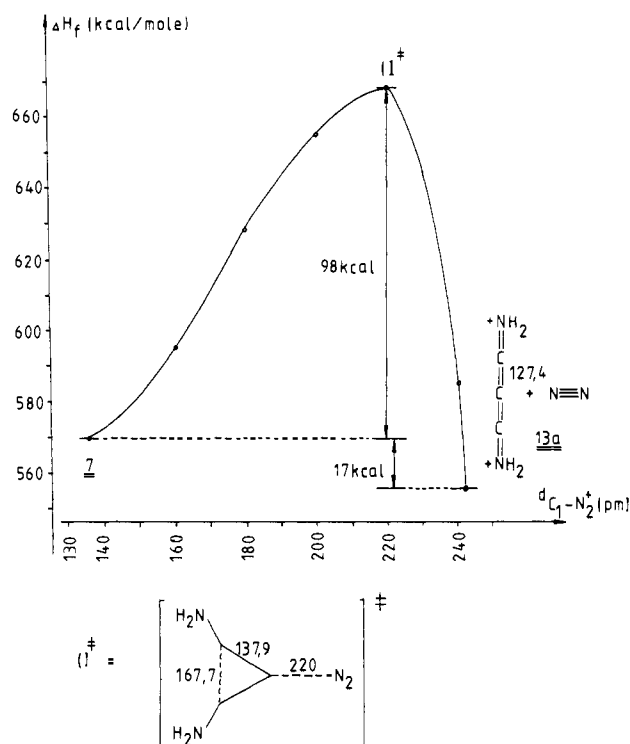

Figure 4. Nonlinear nitrogen extrusion from **7**.

Scheme IV. Linear Nitrogen Extrusion from the Model **7** According to MNDO Calculations



qualitatively makes sense because two very strong bonds have to be broken in the process, namely (a) a  $C_{sp}-N_{sp}$   $\sigma$  bond with additional  $\pi$  overlap orthogonal to it and (b) a  $C-C$  bond of the aromatic cyclopropenium core.

According to these considerations, **1d** has to be generated via a different pathway. Nevertheless, it is noteworthy that the main course of dediazonization of **6d** is tied to a ring-opening process, as evidenced by the total lack of characteristic cyclopropenium ring vibrations in the IR spectra of the dark residue after extraction of **1d**. The ring-opening process according to Scheme IV and oligomers or polymers of cumulated systems **13** (bisiminium salts of  $C_3O_2$ !) may be responsible for these observations.

The only other candidate which seems to have the correct electronic characteristics to function as a precursor for **1d** seems to be the  $S$  state. The three-membered ring would have a highly electrophilic  $\pi$  system (a donor-substituted 1,2,3-tricarbenium ion) according to **14**. Our MNDO model calculations show that this situation is reached by nonlinear nitrogen extrusion in which  $C-N$  cleavage is accompanied by bending of the  $N_2$  moiety in a plane orthogonal to the ring plane (cf. Figure 4).

At a bending angle of  $90^\circ$  (69 kcal/mol above **7**), the system has changed its electronic character considerably. It now rep-

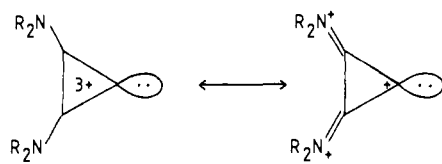

14

resents a weak donor-acceptor complex of nitrogen with the S-carbene, which imparts electrophilic character to C<sub>1</sub>. Further stretching of this weak bond gives nitrogen and the dicationic carbene in its singlet state **14** (S), the energy level of which is 79.6 kcal/mol above the ground state of **7**.

However, the high endothermicity of this unimolecular decomposition pathway to singlet **14** as a potential precursor for **1d** is inconsistent with the formation of **1d** under comparatively mild conditions (80–110 °C) which indicates a much lower *experimental* value for the activation barrier.

The most plausible way out of this dilemma would be a bimolecular substitution pathway within the ion pair **6d**. Our calculations show that out-of-plane bending makes C<sub>1</sub> increasingly more electrophilic (the charge at C<sub>1</sub> becomes increasingly positive at bending angles greater than 45°). At bending angles between about 45° and 60° (corresponding to an energy increase between 21 and 35 kcal/mol), the system has reached a point where it can be viewed as a *pseudo-alkanediazonium ion*, **15**. Instead of following a much more costly S<sub>N</sub>1-type pathway (corresponding to further bending and stretching), an energetically favorable alternative would consist in nucleophilic back-side attack by the SbCl<sub>6</sub><sup>-</sup> counterion, which is held in close proximity by electrostatic forces. This novel S<sub>N</sub>2-like substitution process could then be qualitatively described as in Scheme V. This reaction type could in principle and quite generally be discussed for reactions of diazo compounds with nucleophiles instead of reaction sequences via "free" carbenes, but it is certainly of much higher significance in the above case, where the nucleophile is held in close proximity to the electrophilic center by electrostatic forces in the crystal lattice.

It would be desirable to study dediazonation reactions of **6** in solution. Up to the present time, we were unable to find a solvent which would dissolve salts **6** and yet leave the dication intact. Further efforts in this area are warranted.

**C. Protonation.** The third remarkable reaction type which we encountered when exploring the chemistry of diazonium salts **6** is *reversible* protonation. This was studied in some detail for **6b** and **d**. Addition of a 3–4 M excess of etheral tetrafluoroboric acid to a suspension of **6b** and **d** in dichloromethane converted them in near quantitative yield to bright yellow salts **16**, which analyzed correctly for **6b**·HBF<sub>4</sub> and **6d**·HBF<sub>4</sub>. Which is the Lewis-basic site in **6b** and **d**? First we considered a hydrogen-bonded associate SbCl<sub>6</sub><sup>-</sup>·HBF<sub>4</sub> as a possible source for the uptake of 1 mol of HBF<sub>4</sub> by **6b** and **d**. However, such a hydrogen-bonded system to our knowledge has never been reported, and the fact that normal BF<sub>4</sub><sup>-</sup> and SbCl<sub>6</sub><sup>-</sup> vibrational modes are registered in the IR spectra makes this a very remote possibility. *Therefore one has to discuss the attack of a proton on the organic dication!* The IR spectra taken in KBr and Nujol mull of **16a** and **b** show that the systems maintain a high degree of symmetry during protonation: Only one new IR absorption is observed at 3100 cm<sup>-1</sup> as a sharp band of medium intensity. When treated with diisopropylethylamine, salts **16a** and **b** clearly revert to the starting systems **6b** and **d**, and the IR absorption at 3100 cm<sup>-1</sup> vanishes. These observations and the calculational results (cf. above) confirm that both charge distribution and HOMO structure of the dication favor C<sub>1</sub> protonation by a wide margin over N protonation. The structure of **16** in all likelihood is that of an alkanediazonium ion<sup>20</sup> (eq 7). Full MNDO calculations for the prototypal systems **17a** and **b** strongly support this view. C protonation is indeed favored

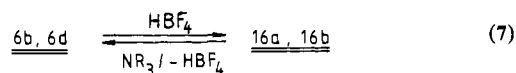

Possible structures:

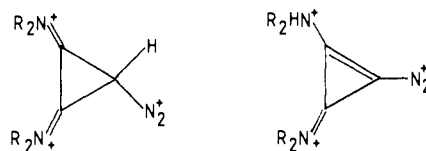

R = i-C<sub>3</sub>H<sub>7</sub>

by more than 30 kcal/mol (Figure 5).

The new IR band at 3100 cm<sup>-1</sup> is compatible with a C–H stretching vibration at a cyclopropyl position.<sup>21</sup> The stability of salts **16a** and **b**, which probably represent the first isolable alkyldiazonium salts,<sup>22</sup> can be easily accounted for by the following considerations: (a) Unimolecular dediazonation according to S<sub>N</sub>1 is not a viable reaction pathway for **16**, as a highly strained and extremely electrophilic species **18** (a derivative of a *tricarbenium ion*), would have to be generated. (b) S<sub>N</sub>2-type dediazonation

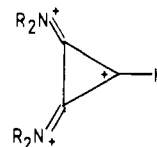

at our reaction conditions is blocked both due to the known reluctance of three-membered rings to undergo S<sub>N</sub>2 reactions and to the absence of nucleophiles.

The main driving force of the reaction could be relief of ring strain (introduction of a tetrahedral center) and formation of a strong C<sub>sp<sup>3</sup></sub>-H bond. Obviously, these two factors are capable of overriding the unfavorable charge repulsion and disruption of the conjugated system in going from **6b** and **d** to **16a** and **b**.

There remain questions, however, concerning the detailed structure of **16a** and **b**. For instance, one might have expected more dramatic IR frequency shifts as a consequence of protonation, but only minor changes are observed. This is particularly noteworthy for diazonium IR vibrational modes which remain virtually unchanged in the process. Possibly the expected shift of the diazonium band to higher frequencies in going from **6b** and **d** to **16a** and **b** is counterbalanced by the concomitant hybridization change at C<sub>1</sub> (C<sub>sp</sub> → C<sub>sp<sup>2</sup></sub>). Unfortunately, the high insolubility of **16a** and **b** has thwarted all attempts to obtain an NMR spectrum. Currently we are approaching the structural problems presented by **16a** and **b** by reacting **6b** and **d** with strong electrophiles other than a proton.

### Experimental Section<sup>23</sup>

**1,2-Bis(diisopropylamino)-3-aminocyclopropenium Tetrafluoroborate (2b).**<sup>9</sup> Through a rapidly stirred solution of 1.793 g (5 mmol) of 1,2-bis(diisopropylamino)-3-chlorocyclopropenium tetrafluoroborate **1d**<sup>24</sup> in

(21) Wiberley, S. E.; Bunce, S. C.; Bauer, W. H. *Anal. Chem.* **1960**, *32*, 217.

(22) McGarrity, J. F.; Cox, P. D. *J. Am. Chem. Soc.* **1983**, *105*, 3961.

(23) All reactions were carried out in dry solvents under nitrogen atmosphere. All melting and decomposition points are uncorrected. Elemental analyses were performed on a Heraeus C-H-N-Mikroautomat. The infrared absorption spectra were determined on Beckman Accu Lab A1 and A3 infrared spectrophotometers. The proton magnetic resonance spectra were determined at 60 MHz by using a Jeol C 60-H spectrometer. <sup>13</sup>C magnetic resonance spectra were determined at 100 MHz on a Jeol PS100 spectrometer. All solvents were dried and purified by column chromatography on basic aluminum oxide "Woelm" or by using standard methods, followed by GC control.

(24) Compare with ref 9.

(20) Friedman, L. In "Carbocation Ions"; Wiley: New York, 1970; Olah, G. A., Schleyer, P. v. R., Eds.; Vol. 2, p 655.

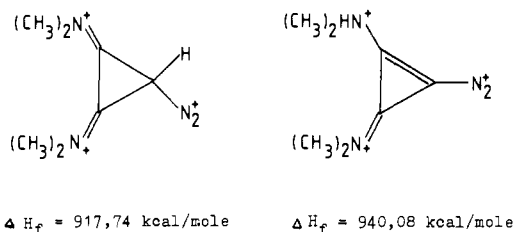
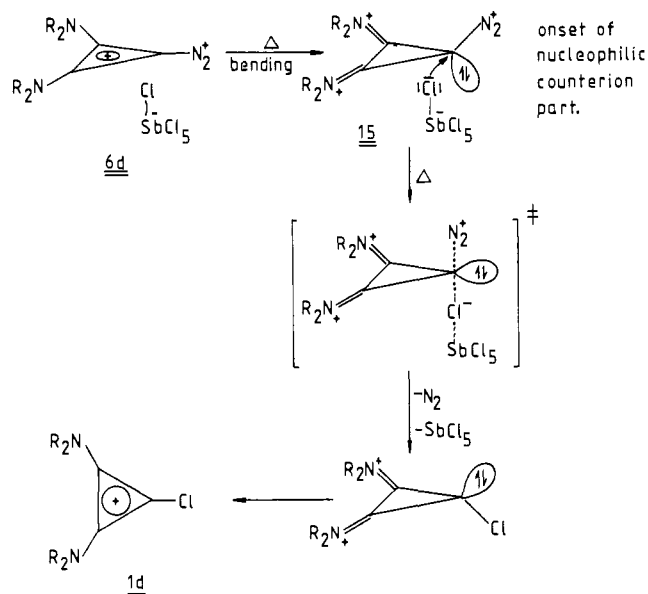

Figure 5. MNDO results for 17.

Scheme V.  $S_N2$ -Type Nitrogen Extrusion from 6d

25 mL of dry dichloromethane at 0 °C, dry ammonia gas is passed for 15–30 min. The reaction temperature should be kept at 5–10 °C in order to avoid larger amounts of byproducts. The ammonium chloride precipitate is filtered off and washed with 10 mL of dichloromethane. The filtrates are collected and evaporated in vacuo at room temperature. The remaining crude **2a** is recrystallized from dichloromethane/diethyl ether to yield 1.628 g (96%) of slightly yellow hygroscopic needles: mp 158–160 °C dec;  $^1\text{H NMR}$  ( $\text{CDCl}_3$ )  $\delta$  1.35 (d, 24 H,  $J = 10$  Hz,  $\text{CH}-\text{CH}_3$ ), 3.85 (m, 4 H,  $\text{CH}-\text{CH}_3$ ), 5.95 (s, br, 2 H,  $\text{NH}_2$ ); IR (KBr) 3390 (NH), 3305 (NH), 3200 (NH), 2975, 1620, 1510 ( $\text{C}_3^+-\text{N}$ ), 1365, 1340  $\text{cm}^{-1}$  and strong tetrafluoroborate absorptions. Anal. Calcd for  $\text{C}_{15}\text{H}_{30}\text{N}_3\text{BF}_4$ : C, 53.11; H, 8.91; N, 12.39. Found: C, 52.74; H, 8.68; N, 12.07.

**1,2-Bis(diisopropylamino)-3-aminocyclopropenium Hexachloroantimonate (2b).** To a solution of 0.288 g (1 mmol) of 1,2-bis(diisopropylamino)-3-aminocyclopropenium chloride **2c**<sup>9</sup> in 20 mL of dry dichloromethane is added dropwise at room temperature a solution of 0.299 g (1 mmol) of  $\text{SbCl}_5$  in 20 mL of the same solvent. **2b** begins to precipitate as a reddish-violet crystal powder. After a reaction time of 8 h, the precipitation of **2b** is completed by addition of 40 mL of *n*-hexane. **2b** is filtered off under nitrogen, washed with 30 mL of dry hexane, and dried in vacuo for several hours, yielding 0.563 g (96%) of a reddish-violet, air- and moisture-stable crystal powder: mp 176–178 °C dec;  $^1\text{H NMR}$  (hot  $\text{CD}_3\text{CN}$ )  $\delta$  1.33 (d, 24 H,  $J = 8$  Hz,  $\text{CH}-\text{CH}_3$ ), 3.82 (m, 4 H,  $\text{CH}-\text{CH}_3$ ), 5.85 (s, br, 2 H,  $\text{NH}_2$ ); IR (KBr) 3475 (NH), 3390 (NH), 2970, 1603, 1530 ( $\text{C}_3^+-\text{N}$ ), 1500, 1450  $\text{cm}^{-1}$ . Anal. Calcd for  $\text{C}_{15}\text{H}_{30}\text{N}_3\text{Cl}_6\text{Sb}$ : C, 30.70; H, 5.15; N, 7.16. Found: C, 30.23; H, 5.07; N, 7.05.

**General Procedure for 1-(tert-Butylamino)-2,3-bis(dimethylamino)-cyclopropenium Salts 3.** To a stirred solution or suspension of 5 mmol of the corresponding chlorocyclopropenium salt **1**<sup>9,25</sup> in 20 mL of dichloromethane was added dropwise a solution of 1.453 g (10 mmol) of (trimethylsilyl)-*tert*-butylamine<sup>26</sup> in 5 mL of the same solvent at room temperature. After 24–48 h, the solvent was evaporated, and the bright yellow oily residue was extracted with 30 mL of diethyl ether. After settlement of the undissolved oil or solid, the solvent was decanted under nitrogen and the product was dried at pressures below 1 torr for 2–3 h

and then recrystallized from small portions of dichloromethane and much diethyl ether. Yields were between 80% and 94%.

**1-(tert-Butylamino)-2,3-bis(dimethylamino)cyclopropenium tetrafluoroborate (3a)** was prepared as described above from 1.233 g (5 mmol) of 1-chloro-2,3-bis(dimethylamino)cyclopropenium tetrafluoroborate (**1a**)<sup>27</sup> with a reaction time of 36 h. **3a** is collected as 1.260 g (89%) of yellowish hygroscopic crystalline solid: mp 80–83 °C dec;  $^1\text{H NMR}$  ( $\text{CDCl}_3/\text{CD}_3\text{CN}$ )  $\delta$  1.40 (s, 9 H, *t*- $\text{C}_4\text{H}_9$ ), 3.20 (s, 12 H,  $\text{N}-\text{CH}_3$ ), 6.65 (s, br, 1 H,  $\text{N}-\text{H}$ ); IR (KBr) 3310 (NH), 2970, 1970 ( $\text{C}_3^+$ ), 1545 ( $\text{C}_3^+-\text{N}$ ), 1425  $\text{cm}^{-1}$  and tetrafluoroborate absorptions. Anal. Calcd for  $\text{C}_{11}\text{H}_{22}\text{N}_3\text{BF}_4$ : C, 46.67; H, 7.83; N, 14.79. Found: C, 46.18; H, 7.51; N, 14.69.

**1-(tert-Butylamino)-2,3-bis(dimethylamino)cyclopropenium hexachloroantimonate (3b)** was prepared as described above from 2.46 g (5 mmol) of 1-chloro-2,3-bis(dimethylamino)cyclopropenium hexachloroantimonate **1c**<sup>25</sup>. After a reaction time of 48 h, 2.495 g (94%) of **3b** is obtained as brownish-violet, air-stable crystals: mp 179–180 °C dec;  $^1\text{H NMR}$  ( $\text{CDCl}_3/\text{CD}_3\text{CN}$ )  $\delta$  1.39 (s, 9 H, *t*- $\text{C}_4\text{H}_9$ ), 3.16 (s, 12 H,  $\text{N}-\text{CH}_3$ ), 6.06 (s, br, 1 H,  $\text{N}-\text{H}$ ); IR (KBr) 3360 (NH), 2955, 1965 ( $\text{C}_3^+$ ), 1550 ( $\text{C}_3^+-\text{N}$ ), 1510, 1410  $\text{cm}^{-1}$ . Anal. Calcd for  $\text{C}_{11}\text{H}_{22}\text{N}_3\text{Cl}_6\text{Sb}$ : C, 24.89; H, 4.18; N, 7.92. Found: C, 24.65; H, 4.01; N, 7.68.

**General Procedure for 1-Hydrazino-2,3-bis(dimethylamino)cyclopropenium Salts 4a and 4c.** To an ice-cooled solution of 5 mmol of the corresponding 1-chloro-2,3-bis(dimethylamino)cyclopropenium salt **1** in 25 mL of dry methanol was added within 5–10 min a solution of 0.865 g (15 mmol) of hydrazine hydrate (85%) in 20 mL of the same solvent. The reaction temperature should be kept at 5 °C. Hydrazine hydrochloride precipitates partially from the orange reaction mixture. Stirring is continued for 10 h and then the solvent is evaporated. The yellow-orange crystalline residue is extracted with 40 mL of dichloromethane under nitrogen. The insoluble hydrazine hydrochloride is filtered off and washed with 15 mL of dichloromethane. The filtrates are collected, and after evaporation of the solvent finally the crude orange product is dried at 35 °C for 6 h at pressures below 1 torr. Further purification was achieved by recrystallization from dry dichloromethane/diethyl ether. The products are hygroscopic and irreversibly oxidizable by oxygen of the air.

**1-Hydrazino-2,3-bis(dimethylamino)cyclopropenium chloride (4a)** was prepared from 0.957 g (5 mmol) of 1-chloro-2,3-bis(dimethylamino)-cyclopropenium chloride **1b**<sup>25</sup> as described above in a yield of 0.601 g (63%) as a bright yellowish-orange crystal powder which is highly hygroscopic and sensitive to oxygen: mp 68 °C dec;  $^1\text{H NMR}$  ( $\text{CDCl}_3$ )  $\delta$  3.15 (s, 12 H,  $\text{CH}_3$ ), 5.90 (s, very br, 3 H,  $\text{NH}_2$ ); IR (KBr) 3230 (NH), 3130 (NH), 2980, 1640, 1560 ( $\text{C}_3^+-\text{N}$ ), 1425, 1400  $\text{cm}^{-1}$ . Anal. Calcd for  $\text{C}_7\text{H}_{15}\text{N}_4\text{Cl}$ : C, 44.09; H, 7.93; N, 29.38. Found: C, 43.80; H, 7.98; N, 29.15.

**1-Hydrazino-2,3-bis(dimethylamino)cyclopropenium tetrafluoroborate (4c)** was prepared from 1.232 g (5 mmol) of 1-chloro-2,3-bis(dimethylamino)cyclopropenium tetrafluoroborate (**1a**) in a yield of 1.016 g (84%) as beige, highly hygroscopic and oxygen-sensitive needles: mp 76 °C dec;  $^1\text{H NMR}$  ( $\text{CDCl}_3$ ) identical with **4a**; the IR (KBr) spectrum is identical with the spectrum of **4a** and contains additional tetrafluoroborate absorptions. Anal. Calcd for  $\text{C}_7\text{H}_{15}\text{N}_4\text{BF}_4$ : C, 34.74; H, 6.25; N, 23.15. Found: C, 33.50; H, 6.02; N, 22.32. According to elementary analysis, the product contains 0.5 mol equiv of water.

**General Procedure for 1-Hydrazino-2,3-bis(diisopropylamino)cyclopropenium Salts 4b and 4d.** To a well-stirred solution of 5 mmol of the corresponding 1-chloro-2,3-bis(diisopropylamino)cyclopropenium salt **1** in 25 mL of dry methanol at room temperature is added within 5 min a solution of 0.865 g (15 mmol) of hydrazine hydrate (85%) in 20 mL of the same solvent. The orange reaction mixture was heated under reflux for about 1 h, and after cooling the solvent was evaporated in vacuo at 30–35 °C. The residue is extracted with 40 mL of dichloromethane, and the insoluble hydrazine hydrochloride precipitate is rapidly filtered off and washed with an additional 10 mL of dichloromethane. After drying with magnesium sulfate, the solvent was evaporated, except a remainder of 5–10 mL. About 40 mL of dry diethyl ether is layered on top of the dichloromethane phase, and solvent diffusion causes the precipitation of large colorless product crystals which are much less sensitive to moisture and oxidation by oxygen of the air than their dimethylamino analogues.

**1-Hydrazino-2,3-bis(diisopropylamino)cyclopropenium chloride (4b)** was prepared from 1.536 g (5 mmol) of 1,2-bis(diisopropylamino)-3-chlorocyclopropenium chloride **1e**<sup>9</sup> as described above, yielding 1.444 g (95%) of a colorless crystalline powder which is moderately stable to air and moisture: mp 167–169 °C;  $^1\text{H NMR}$  ( $\text{CDCl}_3$ )  $\delta$  1.34/1.44 (d, 24 H,  $J = 10$  Hz,  $\text{CH}-\text{CH}_3$ ), 3.98 (m, 4 H,  $\text{CH}-\text{CH}_3$ ), 4.39 (s, br, 2 H,  $\text{NH}-\text{NH}_2$ ), 8.05 (s, br, 1 H,  $\text{NH}-\text{NH}_2$ ); IR (KBr) 3225 (NH), 3144

(25) Weiss, R. *Tetrahedron Lett.* 1979, 3295.(26) Pike, R. M. *J. Org. Chem.* 1961, 25, 232.

(27) Compare with ref 25.

(NH), 2949, 1639, 1515 ( $C_3^+-N$ ), 1367, 1333  $cm^{-1}$ . Anal. Calcd for  $C_{15}H_{31}N_4Cl$ : C, 59.24; H, 10.52; N, 18.41. Found: C, 59.24; H, 10.15; N, 18.47.

**1-Hydrazino-2,3-bis(diisopropylamino)cyclopropenium tetrafluoroborate (4d)** was prepared from 1.793 g (5 mmol) of 1,2-bis(diisopropylamino)-3-chlorocyclopropenium tetrafluoroborate **1d**<sup>28</sup> as described above, yielding 1.612 g (91%) of colorless crystal needles which are stable to air, but hygroscopic: mp 78 °C dec;  $^1H$  NMR ( $CDCl_3$ ),  $\delta$  1.36 (d, 24 H,  $J = 9$  Hz,  $CH-CH_3$ ), 3.95 (m, 4 H,  $CH-CH_3$ ), 4.39 (s, br, 2 H,  $NH-NH_2$ ), 8.05 (s, br, 1 H,  $NH-NH_2$ ); IR (KBr) 3320 (NH), 3295 (NH), 2965, 1635, 1520 ( $C_3^+-N$ ), 1450  $cm^{-1}$  and strong tetrafluoroborate absorptions. Anal. Calcd for  $C_{25}H_{51}N_4B_2F_8$ : C, 50.86; H, 8.82; N, 15.82. Found: C, 50.07; H, 8.65; N, 15.52.

**General Procedure for 1-Hydrazino-2,3-bis(dialkylamino)cyclopropenium Salts 5.** To a well-stirred solution of 5 mmol of hydrazino-substituted cyclopropenium salt **4** in 20 mL of dry dichloromethane or chloroform under nitrogen is dropped at room temperature a solution of 54% ethereal tetrafluoroboric acid in 5 mL of the same solvent; in the case of the chlorides **4a** and **b**, hydrogen chloride is evolved. After 5–8 h, the solvent is removed in vacuo except a remainder of about 5 mL, and the precipitation of the product is completed by addition of 40–50 mL of well-dried diethyl ether. After filtration, the colorless to fairly brownish crude product is recrystallized from dry acetonitrile dichloromethane/diethyl ether. After filtration, the pure product is dried in vacuo at room temperature for several hours. Salts **5** are colorless crystal powders which are extremely hygroscopic.

**1-Hydrazino-2,3-bis(dimethylamino)cyclopropenium bis(tetrafluoroborate) (5a)** is synthesized as described above by addition of 0.701 mL (5 mmol) of 54% ethereal  $HBf_4$  to 1.210 g (5 mmol) of compound **4c** (compare above) or by addition of 1.402 mL (10 mmol) of 54% ethereal  $HBf_4$  to 0.952 g (5 mmol) of compound **4a** (compare above). Each procedure yields 1.517 g (92%) of **5a** as a beige, highly hygroscopic crystal powder: mp 122–124 °C dec;  $^1H$  NMR ( $CDCl_3/CD_3CN$ )  $\delta$  3.17 (s, 12 H,  $N-CH_3$ ), 8.40 (s, br, 1 H,  $NH-NH_3^+$ ), 8.85 (s, br, 3 H,  $NH-NH_3^+$ ); IR (KBr) 3280 (NH), 3150 (NH), 2930, 1990 ( $C_3^+$ ), 1600 ( $C_3^+-N$ ), 1420  $cm^{-1}$  and strong tetrafluoroborate absorptions. Anal. Calcd for  $C_7H_{16}N_4B_2F_8$ : C, 25.49; H, 4.89; N, 16.99. Found: C, 24.81; H, 5.76; N, 16.53.

**1-Hydrazino-2,3-bis(diisopropylamino)cyclopropenium bis(tetrafluoroborate) (5b)** is synthesized as described above by addition of 0.701 mL of 54% ethereal  $HBf_4$  to 1.771 g (5 mmol) of compound **4d** (compare above) or by addition of 1.402 mL (10 mmol) of 54% ethereal  $HBf_4$  to 1.521 g (5 mmol) of compound **4b** (compare above). Each procedure yields 2.144 g (97%) of compound **5b** as a colorless, highly hygroscopic crystal powder: mp 141–143 °C dec;  $^1H$  NMR ( $CDCl_3/CD_3CN$ )  $\delta$  1.40 (d, 24 H,  $J = 10$  Hz,  $CH-CH_3$ ), 3.90 (m, 4 H,  $CH-CH_3$ ), 7.90 (s, br, 1 H,  $NH-NH_3^+$ ), 8.70 (s, br, 3 H,  $NH-NH_3^+$ ); IR (KBr) 3390 (NH), 3160 (NH), 2960, 1935 ( $C_3^+$ ), 1540 ( $C_3^+-N$ ), 1440  $cm^{-1}$  and strong tetrafluoroborate absorptions. Anal. Calcd for  $C_{15}H_{32}N_4B_2F_8$ : C, 40.76; H, 7.30; N, 12.67. Found: C, 40.35; H, 7.19; N, 12.48.

**1-Diazonio-2,3-bis(diisopropylamino)cyclopropenium Bis(hexachloroantimonate) (6d) via Route i.** To a suspension of 0.364 g (1 mmol) of nitrosyl hexachloroantimonate<sup>29</sup> in 5 mL of dry dichloromethane is added a mixture of 0.587 g (1 mmol) of compound **2b** (compare above) and 0.217 g (2 mmol) of chlorotrimethylsilane together in 10 mL of the same solvent. After 36 h of rapid stirring, 30 mL of dry hexane is added, and the slightly beige precipitate is filtered off under nitrogen and washed 3 times with 5 mL of well-dried dichloromethane. The product is dried in vacuo, yielding 0.374 g (40%) of a colorless, slightly hygroscopic crystal powder: mp 96–99 °C dec; no  $^1H$  NMR spectra could be obtained because of rapid decomposition under nitrogen extrusion in all common solvents; IR (KBr) 2960, 2130 ( $N_2^+$ ), 1870 ( $C_3^+$ ), 1570 ( $C_3^+-N$ ), 1455, 1370  $cm^{-1}$ . Anal. Calcd for  $C_{14}H_{28}N_4Cl_2Sb_2$ : C, 19.30; H, 3.02; N, 6.00. Found: C, 19.14; H, 2.93; N, 5.88.

**General Procedure for 1-Diazonio-2,3-bis(dimethylamino)cyclopropenium Salts 6a and b via Route ii.** To a well-stirred suspension of 1 mmol nitrosyl salt in 5 mL of dry dichloromethane under nitrogen at room temperature is added a mixture containing 1 mmol of the corresponding 1-(*tert*-butylamino)cyclopropenium salt **3** (compare above) and 1 mL of chlorotrimethylsilane. Stirring is continued for 48 h. Finally, the product precipitate is filtered off under nitrogen and washed several times with 5 mL of dichloromethane, followed by drying in vacuo below 1 torr for 4–5 h at room temperature.

**1-Diazonio-2,3-bis(dimethylamino)cyclopropenium bis(tetrafluoroborate) (6a) via route ii** is synthesized as described above from 0.283 g (1 mmol) of compound **3a** (compare above) and 0.117 g (1 mmol)  $NOBF_4$ ,<sup>30</sup> yielding 0.303 g (93%) of **6a** as a beige, extremely hygroscopic

crystal powder: mp 51 °C dec;  $^1H$  NMR ( $CD_3CN$ )  $\delta$  3.46 (s, 6 H,  $N-CH_3$ ), 4.08 (d, 6 H,  $J = 2$  Hz,  $N-CH_3$ ). During measurement of the NMR spectrum, **6a** decomposed under nitrogen extrusion and formed of a black solution of as yet unidentified products: IR (KBr) 3095 (hydrolysis product), 2940, 2155 ( $N_2^+$ ), 1650 (hydrolysis product), 1605 ( $C_3^+-N$ ), 1425  $cm^{-1}$  and strong tetrafluoroborate absorptions. Anal. Calcd for  $C_7H_{12}N_4B_2F_8$ : C, 25.81; H, 3.71; N, 17.20. Found: C, 23.40; H, 3.46; N, 13.61. The microanalysis data are correct for 1 bound equiv of dichloromethane.

**1-Diazonio-2,3-bis(dimethylamino)cyclopropenium bis(hexachloroantimonate) (6c) via route ii** is synthesized as described above from 0.531 g (1 mmol) of compound **3b** (compare above) and 0.364 g (1 mmol) of  $NOSbCl_6$ ,<sup>29</sup> yielding 0.780 g (95%) of a slightly beige, hygroscopic crystal powder: mp 73 °C dec; there is no NMR spectrum obtainable because of immediate decomposition in all common solvents: IR (KBr) 3050 (hydrolysis product), 2950, 2145 ( $N_2^+$ ), 1945 ( $C_3^+$ ), 1640 (hydrolysis product), 1600 ( $C_3^+-N$ ), 1430  $cm^{-1}$ . Anal. Calcd for  $C_7H_{12}N_4Cl_2Sb_2$ : C, 10.24; H, 1.47; N, 6.82. Found: C, 9.99; H, 1.52; N, 6.68.

**General Procedure for 1-Diazonio-2,3-bis(dialkylamino)cyclopropenium Salts 6 via Route iii.** To a rapidly stirred solution of 1 mol equiv of hydrazino-substituted cyclopropenium salt **4** (compare above) in 10 mL of dry dichloromethane is poured a solution of 3 mol equiv of  $SOCl_2$  or  $ICl$  in 5 mL of the same solvent. The reaction temperature is not allowed to raise above 20 °C. Immediately, accompanied by gas evolution, some product precipitates. After 5–10 min, 1 mol equiv of acid is added for anion exchange. In case of water-containing acid, to the reaction mixture 1 mL of chlorotrimethylsilane is added before acid addition. Stirring is kept up for 8–10 h, and then all saltlike products are precipitated by addition of 35–40 mL of dry diethyl ether and filtered off under nitrogen. In order to wash out soluble hydrazinocyclopropenium species, the residue is extracted with 35–40 mL of dry dichloromethane in small portions. Finally, the remaining product is dried in vacuo below 1 torr for several hours.

**(a) 1-Diazonio-2,3-bis(dimethylamino)cyclopropenium Salts (6a, 6c).** These products could not be separated from the corresponding protonated hydrazinocyclopropenium precursors.

**(b) 1-Diazonio-2,3-bis(diisopropylamino)cyclopropenium Salts (6b, 6d).** These products are almost insoluble in dichloromethane and can be obtained in pure form by extraction. Yields are higher than via route i (compare above).

**1-Diazonio-2,3-bis(diisopropylamino)cyclopropenium Bis(hexachloroantimonate) (6d) via Oxidation of 4b with  $SbCl_5$ .** To a well-stirred solution of 0.304 g (1 mmol) of **4b** (compare above) in 10 mL of dry dichloromethane is added dropwise a solution of 1.188 g (4 mmol) of  $SbCl_5$  in 10 mL of the same solvent at room temperature. At the beginning of the  $SbCl_5$  addition, the reaction mixture turns red, but this color vanishes rapidly. At the same time, **6d** begins to precipitate. Finally, the reaction mixture is colored yellow with a suspended beige precipitate of **6d**. The product is filtered off under nitrogen, washed with dichloromethane, and dried in vacuo, yielding 0.822 g (88%) of an almost colorless crystal powder: mp 96–99 °C dec; the product is analytically pure and spectroscopically identical with a sample mentioned earlier (compare above).

**General Procedure for 1-Diazonio-2,3-bis(dialkylamino)cyclopropenium Salts 6a–d via Route iv.** To a rapidly stirred solution/suspension of 1 mmol of the corresponding hydrazinocyclopropenium precursor **5** (compare above) in 5 mL of dry dichloromethane are added 0.661 g (4 mmol) of  $ICl$ , respectively, and 0.540 g (0.324 mL, 4 mmol) of  $SO_2Cl_2$  in 10 mL of the same solvent at room temperature. Reaction temperatures higher than 20 °C should be avoided. Rapid stirring is continued for 15–20 h, followed by evaporation of all volatile components in vacuo below 1 torr at room temperature. Further purification is achieved by extraction of the crystalline products 2–3 times with dry dichloromethane/diethyl ether. Finally, **6a–d** are dried in vacuo at room temperature.

Usually, in this way, salts **6a–d** are obtained analytically pure in yields of about 95%. A large variety of anion combinations is possible.<sup>31</sup>

**General Procedure for the Hydrolysis of Salts 6a–c, Giving 2-(Dialkylcarbamoyl)-2-(dialkylamino)vinylidiazonium Salts 8.** To a rapidly stirred suspension of 1 mmol of the corresponding diazonium salt **6** in 40 mL of absolutely dry dichloromethane under nitrogen atmosphere is added 0.018–0.054 g (1–3 mmol) of water at room temperature, and stirring is continued for 2–4 h. Finally, in order to eliminate water, the solution is stirred with powdered calcium chloride for several hours. The drying agent is filtered off and washed with dry dichloromethane. The organic phases are collected and evaporated in vacuo at room tempera-

(28) Compare with ref 9.

(29) Weiss, R.; Wagner, K.-G. *Chem. Ber.* 1984, 117, 1973.

(30) Doyle, M. P.; Bryker, W. J. *J. Org. Chem.* 1979, 44, 1572.

(31) Wagner, K.-G. Ph.D. Dissertation, University of Erlangen, 1984.



ture. The crude product **8** is purified by recrystallization from dichloromethane/diethyl ether or dichloromethane/ethyl acetate/diethyl ether via solvent diffusion (compare above).

Characteristic data of compounds **8a-c** are shown in Table II.

**Thermolysis of 1-Diazonio-2,3-bis(diisopropylamino)cyclopropenium Bis(hexachloroantimonate) (6d).** Solid **6d** (1.866 g, 2 mmol) (compare above) is continuously heated in a Schlenk tube to 130 °C under nitrogen atmosphere for 24 h in an oil bath. Beginning nitrogen extrusion is observed at about 75 °C and was complete after about 30 min. The volume of nitrogen was determined as 44.7 mL which is almost equal to 2 mmol. **6d** turned deeply black within 5 min, finally forming a black, oily foam. After cooling to room temperature, the residue was extracted with dichloromethane, followed by acetonitrile; evaporation of the solution and recrystallization of the brown crystalline residue from dichloromethane/diethyl ether yielded 0.151 g (25%) of bright yellow **1d**<sup>10</sup> which was identified by comparison with an independently synthesized sample.

The residue of the extraction does not show any indication of other cyclopropenium-derived products and seems to consist mainly of a totally insoluble dark polymer.

**Protonation of Diazonium Salts 6b and 6d, Giving Salts 16.** To a well-stirred suspension of 0.933 g (1 mmol) of bis(hexachloroantimonate)

**6d** in 10 mL of dichloromethane under nitrogen is added rapidly 1.405 mL (0.878 g, 10 mmol) of 54% ethereal tetrafluoroboric acid at room temperature, and stirring is continued for 3 h. During this time, the reaction mixture turns dark brown. By addition of 30 mL of *n*-hexane, all saltlike products are precipitated, and the solvent is removed under nitrogen by decantation. The residue is treated with 5 mL of dichloromethane and 30 mL of hexane 3 times in succession. Finally, the remaining precipitate is dried in vacuo below 1 torr at room temperature overnight, yielding 0.468 g (89%) of **16** as a hygroscopic, yellowish-brown crystal powder: mp 79 °C dec; IR (KBr) 3100 (cyclo-C<sub>3</sub>-H), 2975, 2700, 2135 (N<sub>2</sub><sup>+</sup>), 1570 cm<sup>-1</sup> and very strong tetrafluoroborate absorptions. No NMR spectra could be obtained because of immediate decomposition in all common solvents under nitrogen extrusion, resulting in dark oily tars. Anal. Calcd for C<sub>15</sub>H<sub>29</sub>N<sub>4</sub>B<sub>3</sub>F<sub>12</sub>: C, 34.26; H, 5.56; N, 10.65. Found: C, 35.03; H, 5.72; N, 11.08.

The same compound **16** could be obtained analytically pure from analogous treatment of the bis(tetrafluoroborate) **6b** with a 4 M excess of ethereal tetrafluoroboric acid in 94% yield.

**Acknowledgment.** This work was generously supported by the Deutsche Forschungsgemeinschaft and the Fonds der Chemischen Industrie.

## Oxidation-Reduction Reactions of *N*-Sulfonylacetanilides: Mechanisms of the Halide-Induced Reduction of Models for the Carcinogenic Metabolites of Aromatic Amides

Maria Pelecanou and Michael Novak\*

Contribution from the Department of Chemistry, Clark University, Worcester, Massachusetts 01610. Received November 5, 1984.

Revised Manuscript Received March 27, 1985

**Abstract:** The solvent-separated nitrenium ion-sulfate ion pairs generated during the hydrolysis of the *N*-sulfonylacetanilides undergo reduction in aqueous solutions of halide salts. Similar reactions have been explained previously by invoking the intermediacy of an *N*-halo intermediate which undergoes nucleophilic attack by the halide to generate the reduction product and molecular halogen. Several observations made on the reduction reactions of the *N*-sulfonylacetanilides are not entirely consistent with this mechanism. In KCl solution, *N*-sulfonyl-*p*-bromoacetanilide (**1d**) undergoes reduction simultaneously with halogen exchange to yield *p*-chloroacetanilide (**7c**). This same ester is reduced to *p*-bromoacetanilide (**7d**) in KBr. Halogen exchange can be demonstrated in this case also through the use of <sup>79</sup>Br-enriched KBr. These results can be explained by a reduction mechanism involving the intermediacy of an *N*-acetyl-4,4-dihalo-2,5-cyclohexadienimine (Scheme III). This mechanism accounts for 29 ± 8% of the reduction of **1d** in KBr according to the exchange data, so there must be a second mechanism of reduction. This may be the mechanism involving the *N*-halo intermediate, although there is no evidence which requires this conclusion. Radical-trapping studies indicate that neither path involves radical intermediates.

### Introduction

The sulfate esters of *N*-hydroxyacetanilides (**1**: Y = *p*-CH<sub>3</sub>, H, *p*-Cl, *p*-Br, *m*-Br, 3,4-diCl) serve as models for the carcinogenic metabolites of aromatic amides.<sup>1</sup> In aqueous solution these

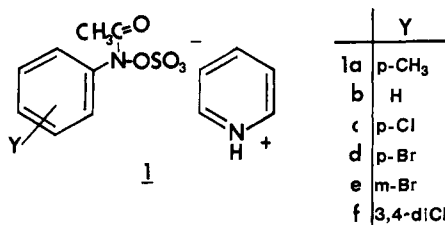

compounds generate both intimate nitrenium ion-sulfate ion pairs

(1) Several recent reviews include: Miller, J. A. *Cancer Res.* **1970**, *30*, 559-576. Kriek, E. *Biochim. Biophys. Acta* **1974**, *355*, 177-203. Miller, E. C. *Cancer Res.* **1978**, *38*, 1479-1496. Miller, E. C.; Miller, J. A. *Cancer* **1981**, *47*, 2327-2345.

which lead to rearranged products, and solvent-separated ion pairs which can be trapped by various reagents.<sup>2,3</sup> The closely related methanesulfonate esters of *N*-hydroxyacetanilides also decompose via nitrenium ion pathways.<sup>4</sup>

Reduction of **1** to the corresponding acetanilide occurs in aqueous solution in the presence of I<sup>-</sup>, Br<sup>-</sup>, and a number of other reagents. This reduction is also a characteristic reaction of *N*-acyloxypurines and *N*-acetoxy-*N*-arylamides such as *N*-acetoxy-*N*-acetyl-2-aminofluorene.<sup>5,6</sup> Although it is not known what role,

(2) Novak, M.; Pelecanou, M.; Roy, A. K.; Andronico, A. F.; Plourde, F. M.; Olefirowicz, T. M.; Curtin, T. J. *J. Am. Chem. Soc.* **1984**, *106*, 5623-5631.

(3) Novak, M.; Roy, A. K. *J. Org. Chem.* **1985**, *50*, 571-580.

(4) (a) Gassman, P. G.; Granrud, J. E. *J. Am. Chem. Soc.* **1984**, *106*, 1498-1499. (b) Gassman, P. G.; Granrud, J. E. *Ibid.* **1984**, *106*, 2448-2449.

(5) (a) Templeton, M. A.; Parham, J. C. *J. Org. Chem.* **1978**, *43*, 544-550.

(b) Parham, J. C.; Templeton, M. A.; Teller, M. N. *J. Org. Chem.* **1978**, *43*, 2325-2330. (c) Parham, J. C.; Templeton, M. A. *Ibid.* **1982**, *47*, 652-657.

(6) (a) Stroher, G.; Salemnick, G. *Cancer Res.* **1975**, *35*, 122-131. (b) Brown, G. B.; Teller, M. N.; Smullyan, I.; Birdsall, N. J. M.; Lee, T.-C.; Parham, J. C.; Stroher, G. *Ibid.* **1973**, *33*, 1113-1118. (c) Parham, J. C.; Templeton, M. A. *Ibid.* **1980**, *40*, 1475-1481.